

HBP HIGH BAY LIGHT

150W~300W POWER ADJUSTABLE



- Occupancy Microwave Sensor Option
- Remote Control
- Power Adjustable

NEW

PRODUCT NUMBER BUILDER

Example: STLHBPADJ1504YKBK

SOLTECH High Bay HBP 150 watt power adjustable, 4000K, Yoke installation, with a black finish.

SERIES	WATT (W -8%~+5%)	COLOR TEMP (X)	MOUNTING OPTIONS (YY)	FINISH (ZZ)	VOLTAGE (V) (Blank)	OPTIC TYPE (Blank)	DIMMING (Blank)
--------	------------------	----------------	-----------------------	-------------	---------------------	--------------------	-----------------

STLHBPADJ	150	3=3,000K	YK=YOKE	BK=BLACK	100-277	90°	0-10V/PWM/VR
	230	4=4,000K	HK=HOOK		277-480		
	300	5=5,000K					

TECHNICAL SPECIFICATIONS

HOUSING	ADC12 aluminum heat sink, Outdoor powder coating.
VOLTAGE	100-277V, 277-480V 60Hz AC
LED	LumiLEDs
EFFICACY	135 LM/W
LUMENS@5000K	10,800-40,500 lumens
POWER FACTOR	≥0.9
BEAM ANGLE	90°
THD	<20%
OPERATING TEMP	-40°F-122°F
ALUMINUM LED BOARD	High conductive, Waterproof, Aging resistance, Salt mist resistance, Long-life.
CONTROLS / DIMMING	0-10V Dimming
CCT	3,000K 4,000K 5,000K
CRI	>80
RATED LIFE	70,000 hours

PRODUCT PARAMETER

MODEL	DIMENSION (in)	VOLTAGE (V)	WATT	POWER ADJUSTABLE	LUMENS @ 5000K(Lm) MAX	EFFICACY (Lm/w)	OPTIC TYPE	DIMMING
STLHBP150XYZZ	7.8X12.6 in	100-277	150	80W 100W 150W	20,250	135	90°	0-10V/PWM/VR
STLHBP230XYZZ	7.8X14.2 in	100-277 277-480	230	100W 150W 230W	31,050	135	90°	0-10V/PWM/VR
STLHBP300XYZZ	8.0X15.7 in	100-277 277-480	300	150W 200W 230W 300W	40,500	135	90°	0-10V/PWM/VR

DIMENSIONAL DRAWING

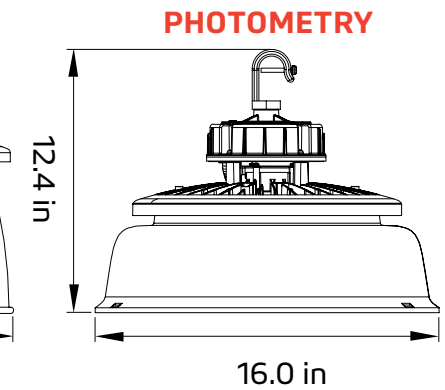
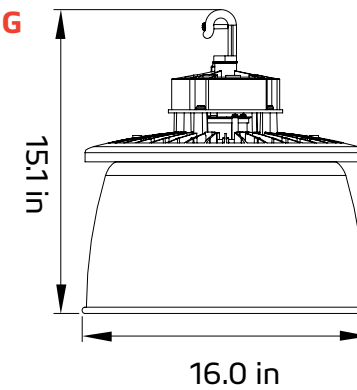
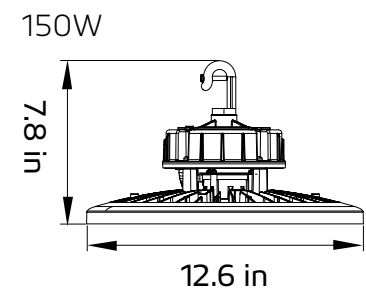

PHOTOMETRY

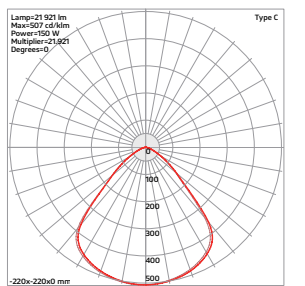

DIMENSIONAL DRAWING

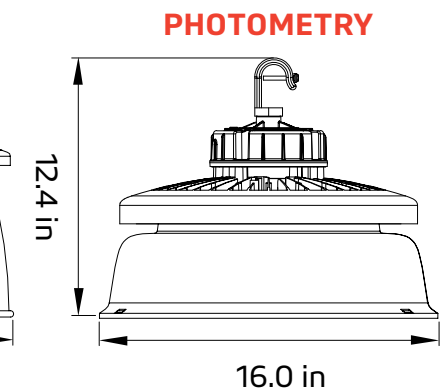
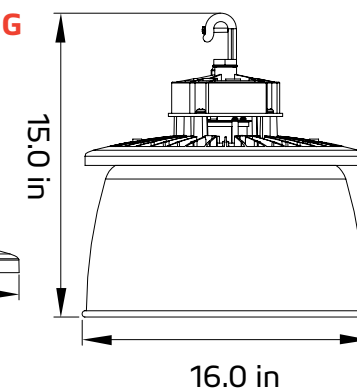
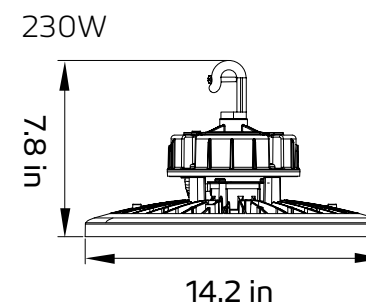

PHOTOMETRY

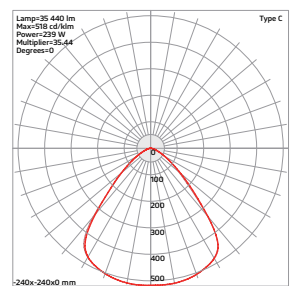

DIMENSIONAL DRAWING

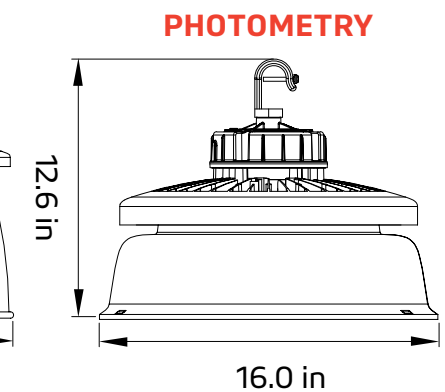
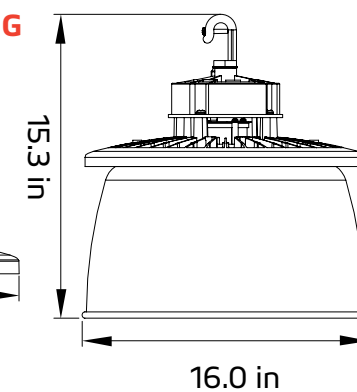
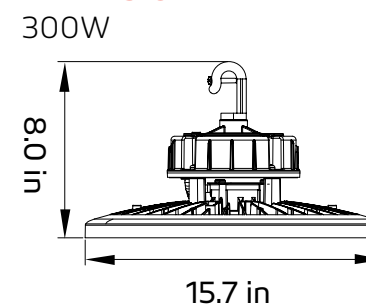

PHOTOMETRY

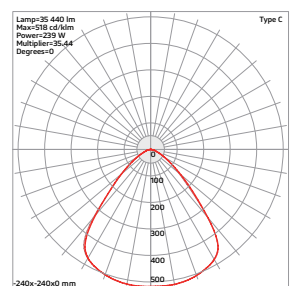

Accessories Guide—High Bay HBP

POWER ADJUSTABLE

For more information, please visit our website:
www.soltechlighting.com



WATT/CCT ADJUST

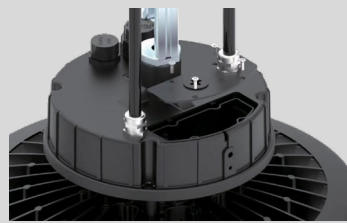

CONNECTING BOX



150W 135lm/W
 Dimension: 7.8in x 12.6in

230W 135lm/W
 Dimension: 7.8in x 14.2in

300W 135lm/W
 Dimension: 8.0in x 15.7in

Ambient Temp.: -40–122°F

Plug In Type Sensor:
 Microwave Sensor.

100–277V, 277–480V suitable for
 warehouse, supermarket locations.

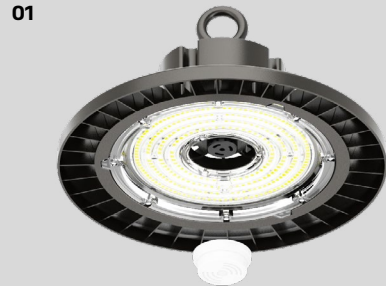

01

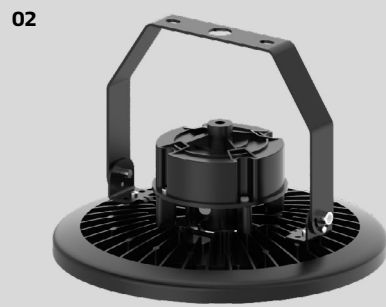

02



03

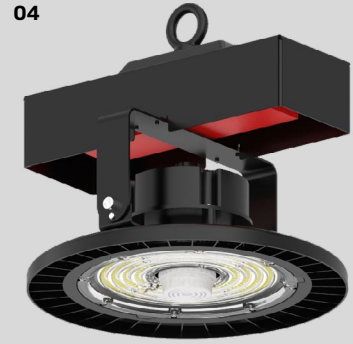

04

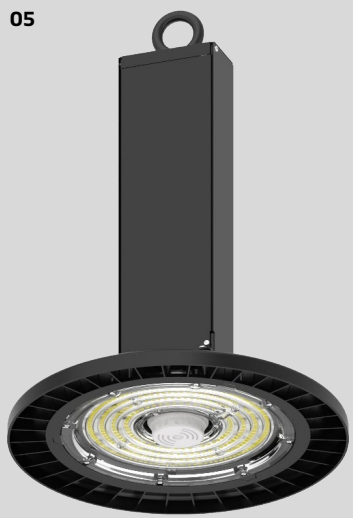

05

01 Plug In Type Sensor	04 Emergency Battery Pack
02 Bracket Mounting	05 High Temperature/ High Voltage Driver
03 Anti-glare PC Reflector	



HBP PARTS LIST

ILLUSTRATION	HOOK INSTALLATION	YOKE INSTALLATION
A. HOUSING 	A+B+I	A+C+I
B. HOOK/RING 		
C. YOKE 	A+B+E+J A+B+F+J	A+C+E+J A+C+F+J
D. TYPE A PC BOTTOM COVER (16") 		
E. ALUMINUM REFLECTOR (16") 	A+B+G	A+C+G
F. PC REFLECTOR (16" Large) 		
G. PC REFLECTOR (16" Small) 	A+B+G+D	A+C+G+D
H. TYPE Y PC BOTTOM COVER (16") 		
I. WIRE (16") 	A+B+G+H	A+C+G+H
J. ADAPTER * For Aluminum reflector and Large PC reflector. 		

*HBP 150W–230W needs **ADAPTER RING** when installing the aluminum reflector and large PC reflector.